

The logo for MEC AV features a stylized 'M' on the left, composed of horizontal lines of varying lengths that create a digital or mechanical appearance. To the right of the 'M', the letters 'E', 'C', 'A', and 'V' are displayed in a clean, sans-serif font. The 'E', 'C', and 'A' are purple, while the 'V' is a greyish-blue color. The entire logo is set against a background of technical drawings and a metallic part.

MECAV

mecânica avançada

MECHANICAL SERVICES WHEN YOU NEED THEM

Precision machining of unique parts, prototypes, short series
Design and manufacture of machines and tools

MECHANICAL SERVICES

The company is committed to a model of service to the industry that allows our customers to increase their added value: quality, precision, competitiveness, personalized service and **punctual delivery**, meeting schedules in order to deliver projects on time.

Precision machining of unique parts, prototypes, short series

We manufacture precision machined parts of any material (special steel, stainless steel, aluminium, technical plastics, titanium, bronze, brass...), and also with a wide range of surface treatments.

We are ready to manufacture complex parts with high demands on precision and critical lead times.

We help our customers to develop their prototypes, assessing them about materials or geometries that can fit better with the needs of the project.

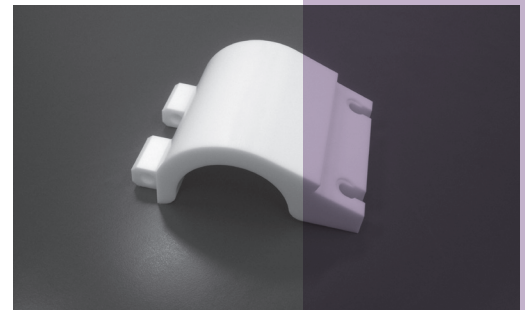
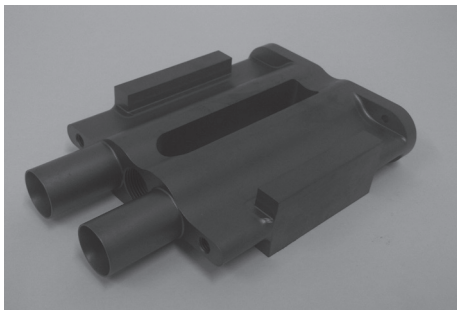
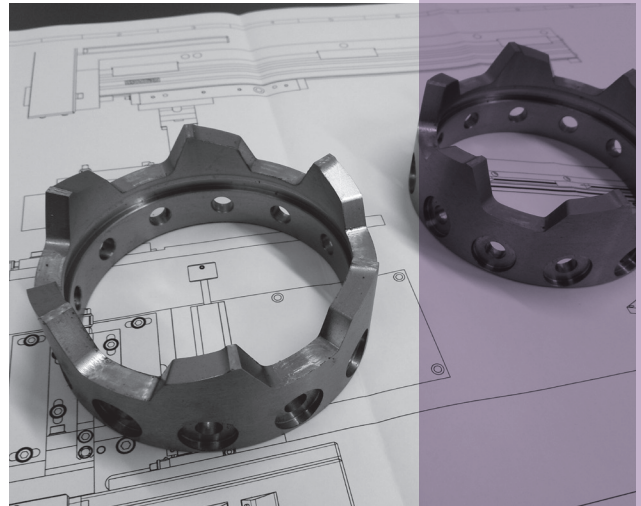
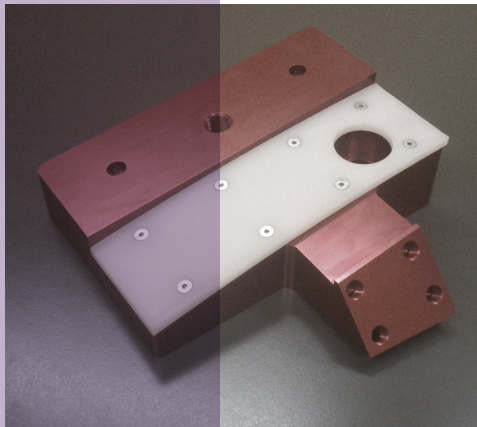

Design and manufacture of machines and tools

We offer an individualized service of custom made machines, tools and means of production.

We develop turnkey projects, from conceptualization and design to manufacture and assembly, as well as the start-up of the machine and the elaboration of the final documentation.

We manage all the technical scope of the project: mechanical, electrical and control (PLC programming, optical detection, artificial vision...). Not only at design level but also in manufacturing and assembly.

We comply with the schedule of the projects to deliver them on time, with strict deadlines which are essential for our customers.

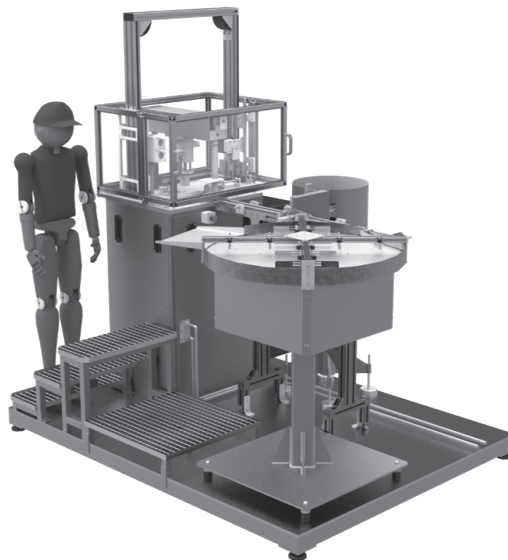
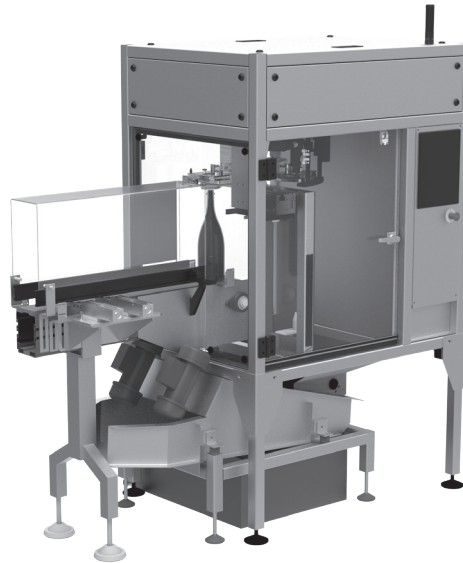

Our bet is reliability and flexibility to help our clients in their projects, achieving high quality standards and **fitting the delivery terms.**

We are your partner

Our relation with our clients is based on trust and reliability, security and confidentiality. Constant communication and contact are our main tools to success.

We achieve their high requirements on surface finishes and quality by knowing thoroughly their way of working and needs.

We offer our experience in the integration of all production processes, from design to manufacturing, improving the competitiveness of our customers.

Our international projection and strong presence in the local market can only be achieved thanks to the flexibility of the method of work and the enthusiasm and commitment of the entire team.

Aeronautics

We produce precision prototypes and sets for ground equipment.

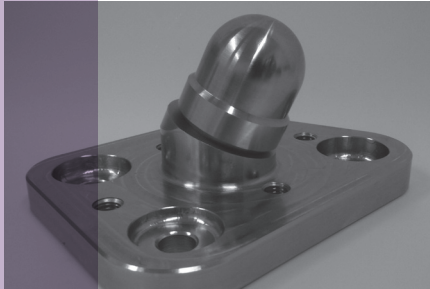
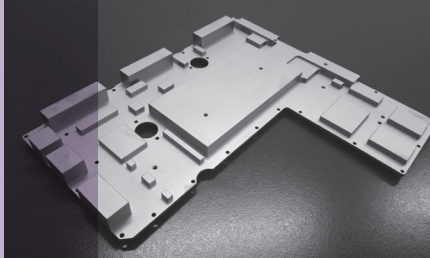
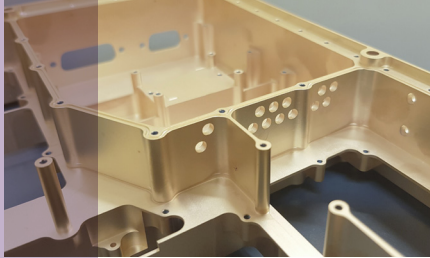
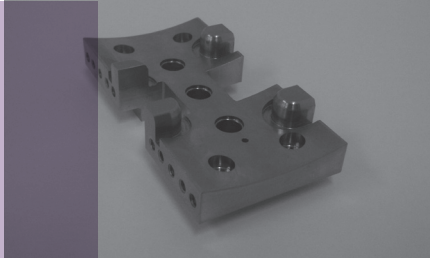

Industrial

We work for several industrial sectors as automotive, alimentary or packaging.

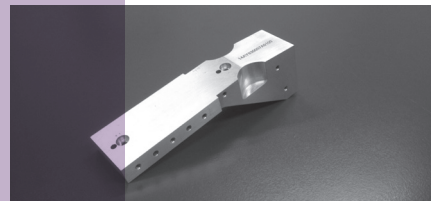
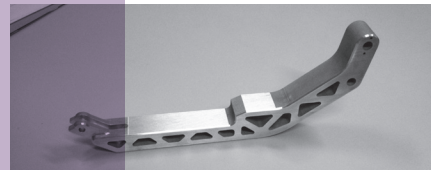
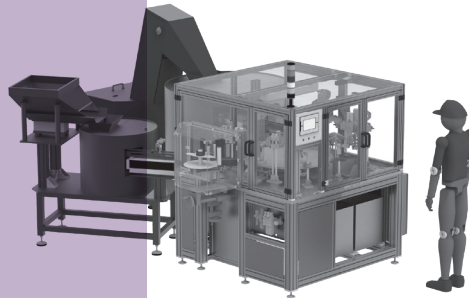
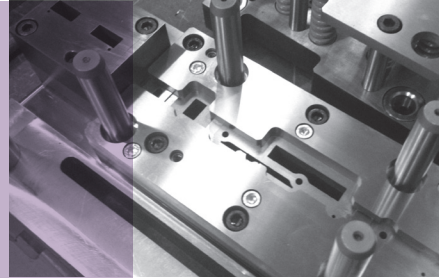

Medical

Our experience in medical sector is mainly with companies involved in the field of:

Research and diagnosis
Laboratory equipment
Laboratory reagents
Chemical research

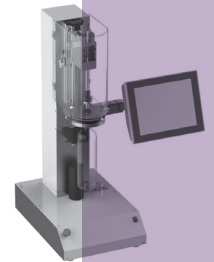
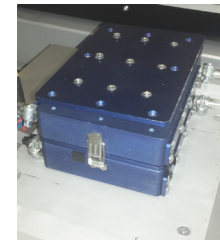
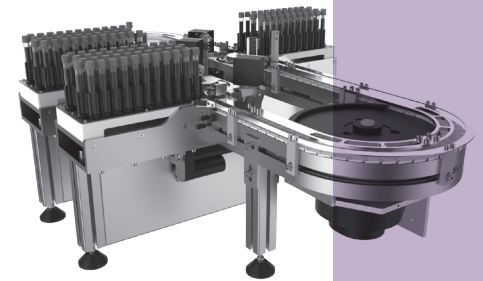
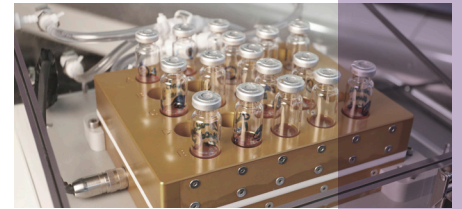

...WHEN YOU NEED THEM

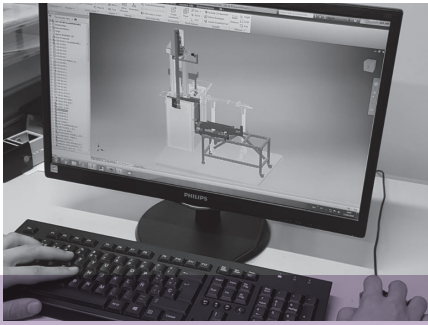

Engineering

We have an engineering department in charge of: design, materials research, solutions development and project management.

We work with our clients as a partner, what leads to a whole interpretation of the project aim and of the customer's needs.

We work according to a plan developed together with the clients, so that they can follow or intervene in the implementation at each step of the process.



Quality

Our Quality Policy is based on providing customer satisfaction by ensuring compliance with all technical requirements and delivery times.

We check the quality of all parts in each step of production process, after treatment, and also before shipping.

We work to improve our system continuously to make it safer and more reliable, taking responsibility for all internal and external processes.

Technical office

The strong technical character of the team and their experience allows us providing complete service for projects and industrial solutions: consulting, implementation and manufacturing.

To achieve our objectives, flexibility is very important. This is why we bet for a very horizontal structure based on technicians with high experience in CNC machines, working with autonomy and self-management to ensure the same level of service during the whole productive day, that covers practically 16 hours.

Traceability

As we know this aspect is essential for sectors for which we work, we ensure full traceability regarding materials and processes, helped by an ERP that enables us to manage the whole chain.

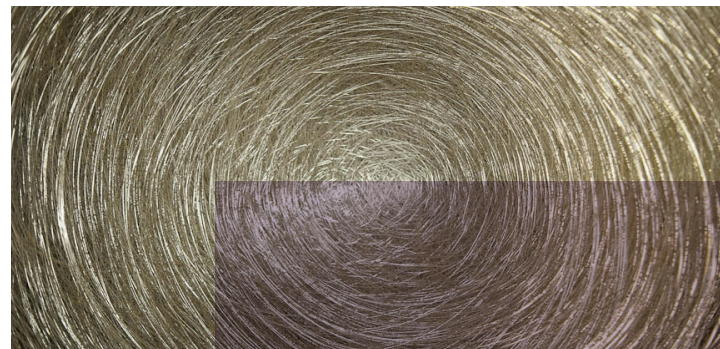
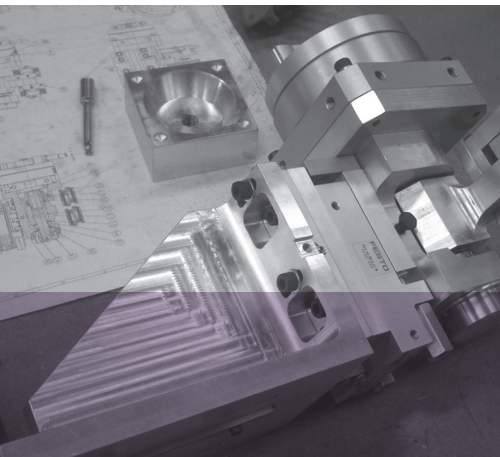

Technology

We work with CAD / CAM software CIMATRON for 3D design, machining, rendering and simulation.

We work with CNC machines for milling, turning and also for wire EDM machining.

Our highly automated fleet of machines is completed with conventional machines.

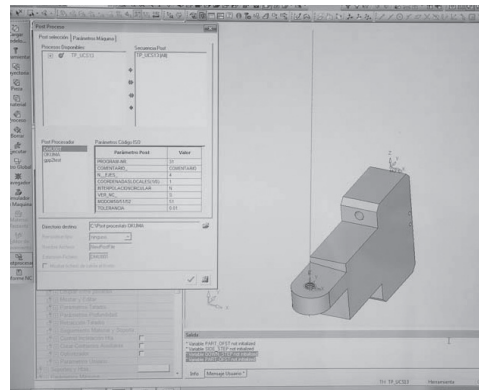

CNC machining center 5-axis HAAS.....Travel (X/Y/Z) 762/508/508 mm.
CNC machining center 4 – axis DECKEL MAHO...Travel (X/Y/Z): 850 / 600 / 600 mm.
CNC machining center OKUMA.....Travel (X/Y/Z): 1050 / 560 / 450 mm.
CNC machining center MORI SEIKI.....Travel (X/Y/Z): 550 / 400 / 500 mm.
2 CNC machining centers HAAS.....Travel (X/Y/Z): 762 / 406 / 508 mm.
2 CNC lathe MORI SEIKI.....Max. swing: 430 mm. / Max. length: 520 mm.
2 Wire EDM machines AGIE.....Travel (X/Y/Z): 400 / 250 / 250 mm.
Sinker EDM machine CHARMILLES.....Travel (X/Y/Z): 320 / 250 / 250 mm.
Tangential grinding machine ZIERSCH BALTRUCH...Max. grinding surface: 400 x 250 mm.



Contact



MECAV
mecànica avançada

Mecànica Avançada S.L.

C/ Irlanda, 18 – Polígon Constantí
43120 CONSTANTÍ
(Tarragona) Spain

Tel: +34 977 100 616

comercial@mecav.eu

www.mecavprecision.com